

**All-in-one for valuable
GPS interference testing**

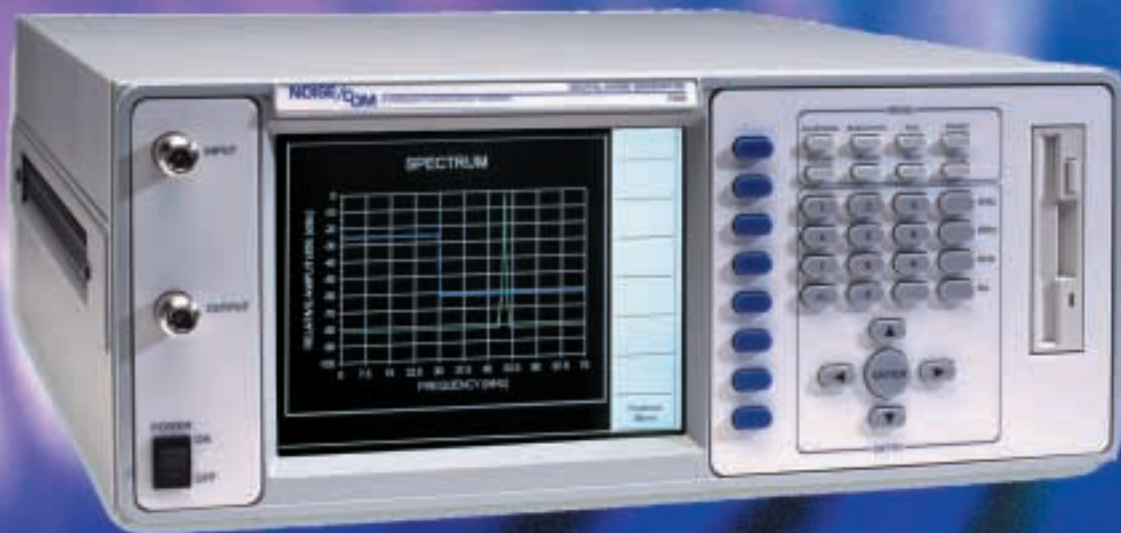

GPS7500 Noise & Interference Generator

GPS7500 Noise & Interference

The Noise Com GPS7500 Noise & Interference Generator is capable of generating up to 40 MHz bandwidth of arbitrary waveforms for the test of susceptibility of GPS receivers to jamming, pulsed, CW, noise and any interference which we could imagine. A modular approach provides for expandability with additional independently programmable generators for L1, L2 or L5 bands. This unique combination allows for a single instrument to support today's as well as possible future GPS standards.

Benefits:

Integrated Approach: Contains one or optionally two independent arbitrary waveform generators. This allows for simultaneous testing of the L1 and L2 or L5 frequencies.

Value: Built-in GPS signal and interference combiner, Gaussian noise source and power meter for automatic high and low power level calibrations.

Protected Investment: As additional independent bands are needed the GPS7500 can be easily upgraded. Arbitrary waveform generator allows creation of any interference or jamming waveform which we could image.

True "Standard" for GPS: The GPS7500 was designed to support all of the current GPS tests of susceptibility to noise and interference of DO-229, DO-235 and DO-253.

Ease of use: Access table of pre-stored GPS testing parameters made by pressing one button. Cursors automatically lead to GPS standard template, giving the operator a quick view of all necessary test criteria.

Technical Features:

- +21 dBm Output Power
- 1000 to 2000 MHz Synthesizer
- 40 MHz Arbitrary Waveform
- 164.5 dB On/Off Ratio
- +/-0.5 ppm over 0 to 50°C

Applications:

GPS Receiver Test and Jamming to:

- RTCA DO-229, DO-235 & DO-253
- Galileo
- GLONASS
- Automotive Standards
- Mobile Phone Location and E911 Services

Noise Com's GPS7500 Noise and Interference Generator was designed to support all the GPS testing requirements in an easy to use platform. Testing receiver susceptibility to interference, intentional or unintentional, has become a requirement and product differentiator in airborne, automotive, defense and mobile phone applications.

While the GPS7500 has been designed around the airborne GPS Standards, DO-253A, DO-235A and DO-229C with a federal agency as a lead customer, these standards are among the most commanding. Based on Noise Com's digital noise and arbitrary waveform technology, GPS7500 may generate any GPS interference waveform which we could imagine. It is therefore easily applicable to GPS receiver, chip set and system susceptibility testing in airborne, automotive, defense, mobile location and E911 services.

GPS7500 allows for user preset and user defined arbitrary interference and jamming waveforms. Automatic testing parameters for several known GPS requirements have been pre-stored and are available to the operator for ease of use.

The higher bandwidth (>40 MHz) of the GPS7500 allows for interference generation over the entire band. With the two-channel option, measurements can be made simultaneously with independent waveforms at L1 and L2 or L5 over this higher bandwidth.

Built-in calibration and an onboard power meter ensure that measurements will always be accurate. A true Gaussian noise source provides a fixed low level reference to which the output power of the arbitrary waveform can be calibrated. A built-in power meter assists in this calibration as well as in the setting of high output power levels up to +21 dBm.

The GPS7500 has three main modes:

- Continuous Wave (CW) Synthesized.
- Arbitrary Interference including Broadband Gaussian Noise.
- Pulse Mode.

Any arbitrary interference waveform which we could imagine may be generated in the Arbitrary Interference Mode. These waveforms, which may include sine waves, noise, AM etc., can then be pulsed at any duty cycle between 0 and 100% at 6.67 nanoseconds resolution. The pulse on/off ratio of 164.5 dB is obtained in a proprietary switch design also includes circuitry for the reduction of frequency splatter.

The embedded PC allows for user defined waveforms as well as custom programming. The Ethernet port supports connection to a LAN and a TCP/IP command set for remote control.

Modular design allows for a number of options, including dual channels (L1, L2 or L5) and built-in low phase noise synthesizer. An optional GPS signal splitter with dual outputs for both an isolated clean reference output and an interference plus GPS combined output is also available.

Generator

Examples of RTCA test cases supported by the GPS7500:

Test Case	Frequency (MHz)	Noise Bandwidth	Power (dBm)	Pulse Width	Duty Cycle	Notes
Broadband Interference:	1575.42	100 kHz	-110.5	N/A	100%	
	1575.42	20 MHz	-97.5	N/A	100%	
Continuous Wave Interference (CWI):	1525.0	CW	-12.0	N/A	100%	
	1555.42	CW	-89.5	N/A	100%	
	1575.41998	CW	-120.5	N/A	100%	
	1595.42	CW	-89.5	N/A	100%	
	1610.00	CW	-30.0	N/A	100%	
	1618.00	CW	-12.0	N/A	100%	
GPS at Maximum Power Level:	1626.00	CW	+8.0	N/A	100%	Only aircraft with SATCOM
	1575.42	100 kHz	-110.5	N/A	100%	At maximum GPS RF power
Pulse Interference:	1575.42	20 MHz	-97.5	N/A	100%	At maximum GPS RF power
	1575.42	100 kHz	+20	1 ms	10%	
	1575.42	100 kHz	+20	125.0 us	10%	Only GPS & WAAS Combo

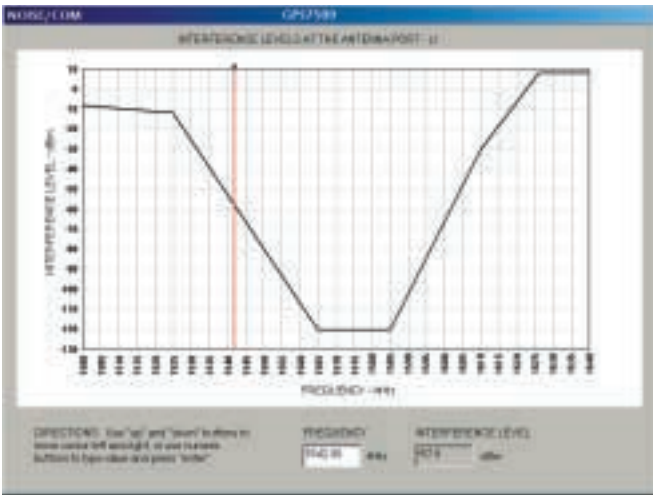

Interference Level vs. Frequency
CLICK TO VIEW LARGER SCREEN

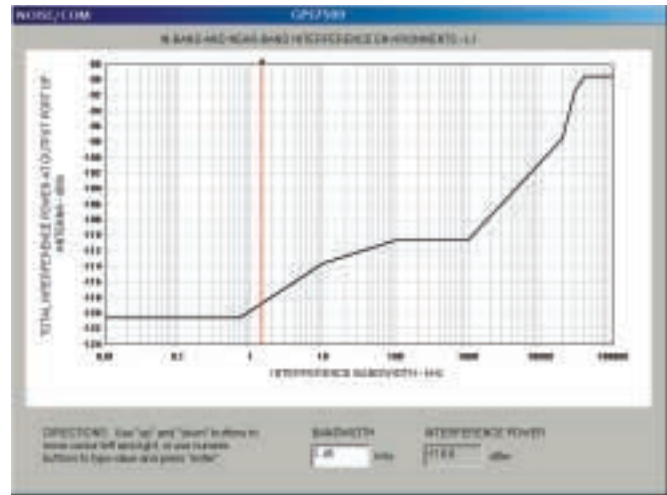

Interference Level vs. Interference Bandwidth
CLICK TO VIEW LARGER SCREEN

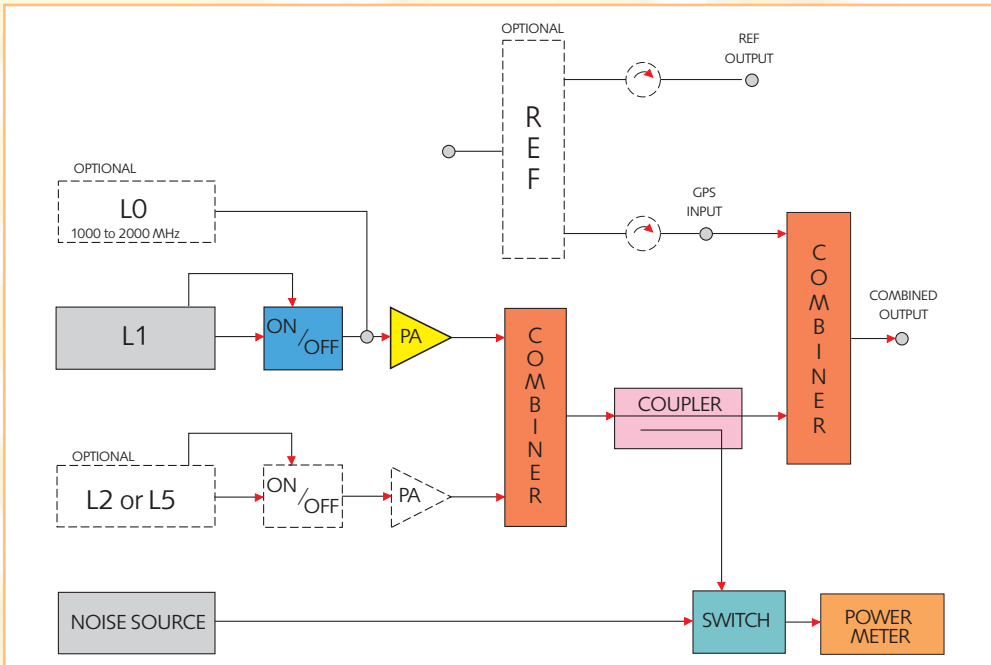

GPS7500 and options

For more information, call 201-261-8797

Specifications

Description	Specification	Notes
CW Operating Frequency Range	1000 MHz to 2000 MHz	Internal Synthesizer
Noise and Pulse Interference Center Frequencies	1575.42 MHz (L1) and optionally 1227.60 MHz (L2) or 1176.45 MHz (L5)	Tunable over +/-20MHz for each Band
Arbitrary Signal (AM, Noise, Pulse) 3dB Bandwidth	0 to 40 MHz	
Frequency Stability	+/- 0.5 ppm	Over 0 to 55 degrees C
Minimum Frequency Resolution	20 kHz	
Phase Noise	-46 dBc/Hz at +/- 20 kHz Offset -122 dBc/Hz at +/- 100 kHz Offset	Maximum All Modes Typical CW Mode
Typical Spurious Output	-52 dBc at <+/- 21.5 MHz Offset -80 dBc at >+/- 21.5 MHz Offset	All Modes CW Mode
Maximum Spurious Output in CW Mode	-122.5 dBc between 1564.42 MHz and 1586.42 MHz	For CW signal at < 1525 MHz or > 1610 MHz
Available Output Power	+10 dBm at 1000 to 2000 MHz +21 dBm at 1555 to 1595 MHz	After internal GPS plus Interference Combiner
Lowest Output Power	-126.5 dBm -170.5 dBm/Hz	All Modes Noise Mode
Output Power Resolution	0.1 dB	
Interference/Signal Ratios	Up to 155 dB	Relative to -134.5 dBm GPS Signal
Minimum Pulse On/Off Ratio	164.5 dB	In Pulse Mode, 1575 to 1595 MHz, > +20 dBm.
Pulse Duty Cycle	0 to 100%	
Pulse Width Resolution	6.67 ns	
Pulse Repetition Rates	5 Hz to 75 MHz	
Maximum CW, Noise or Pulse Power at GPS Input	-41.25 dBm/MHz	Isolation to GPS Input

General

Processor	Pentium	
Operating System	XP	
Display	8.4" TFT-LCD Color	
Remote Interface	Ethernet	GPIB Optional
External Reference Input	10 MHz	Internal/External Reference is software selectable

Ordering Information

Part Number	Description
GPS7500	Noise & Interference Generator for GPS Testing at L1 Band, 1575.42 MHz +/- 20 MHz.
GPSoptLO	Internal 1 GHz to 2 GHz Synthesized LO with selectable by-pass of L1 Filter.
GPSoptL2	Additional independently programmable Noise and Interference Generator for L2 band, 1226.20 MHz +/- 20 MHz.
GPSoptL5	Additional independently programmable Noise and Interference Generator for L5 band, 1176.45 MHz +/- 20 MHz.
GPSoptREF	GPS Signal Splitter with Isolated GPS Output for Reference Receiver.

25 Eastmans Road
 Parsippany, NJ 07054
 Phone: (201) 261-8797
 Fax: (201) 261-8339
 Email: info@noisecom.com
 Web site: www.noisecom.com

NOISE/COM
 A WIRELESS TELECOM GROUP COMPANY

INTERFERENCE LEVELS AT THE ANTENNA PORT - L1

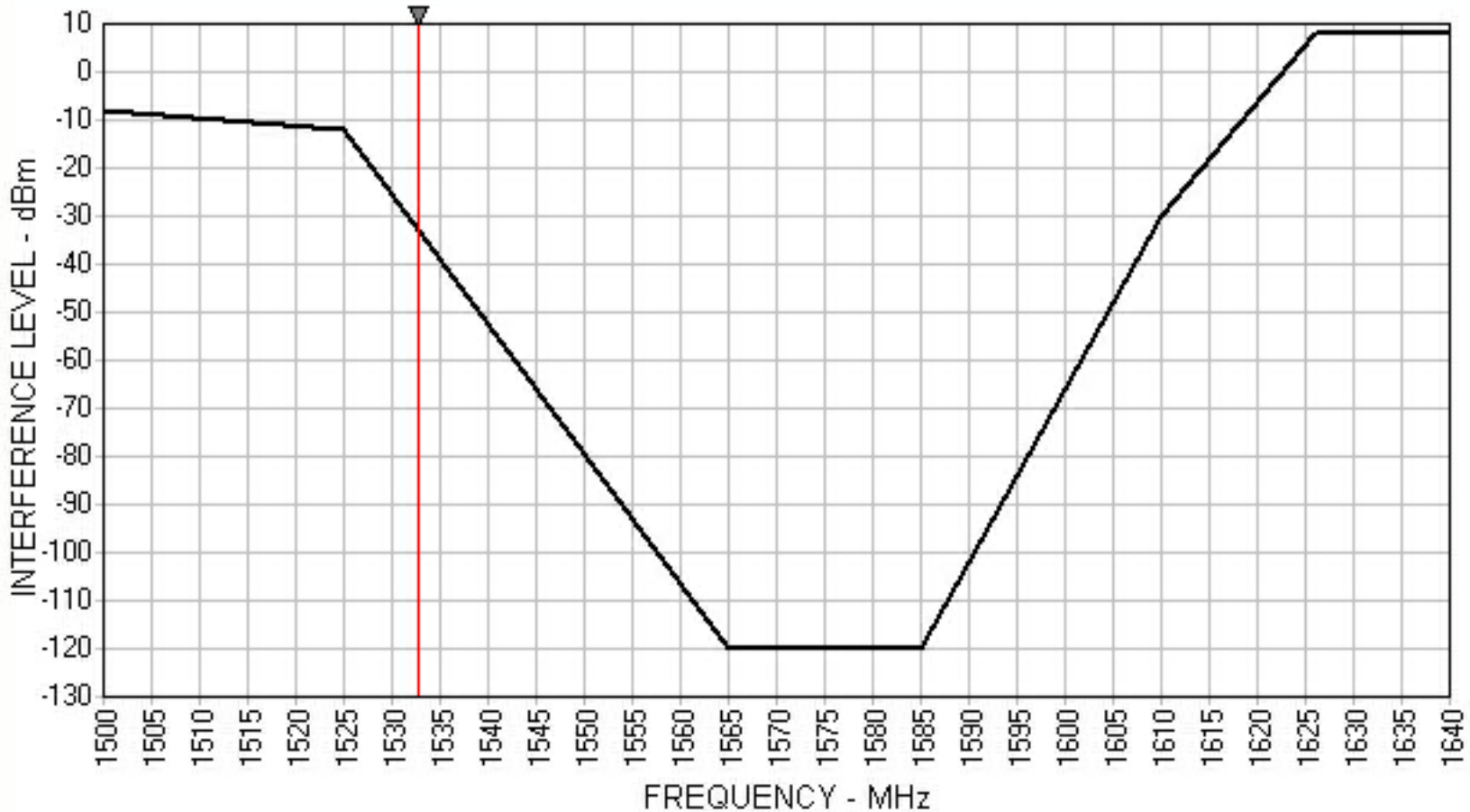

DIRECTIONS: Use "up" and "down" buttons to move cursor left and right, or use numeric buttons to type value and press "enter"

FREQUENCY

1532.75 MHz

INTERFERENCE LEVEL

-32.9 dBm

Interference Level vs. Frequency

IN-BAND AND NEAR-BAND INTERFERENCE ENVIRONMENTS - L1

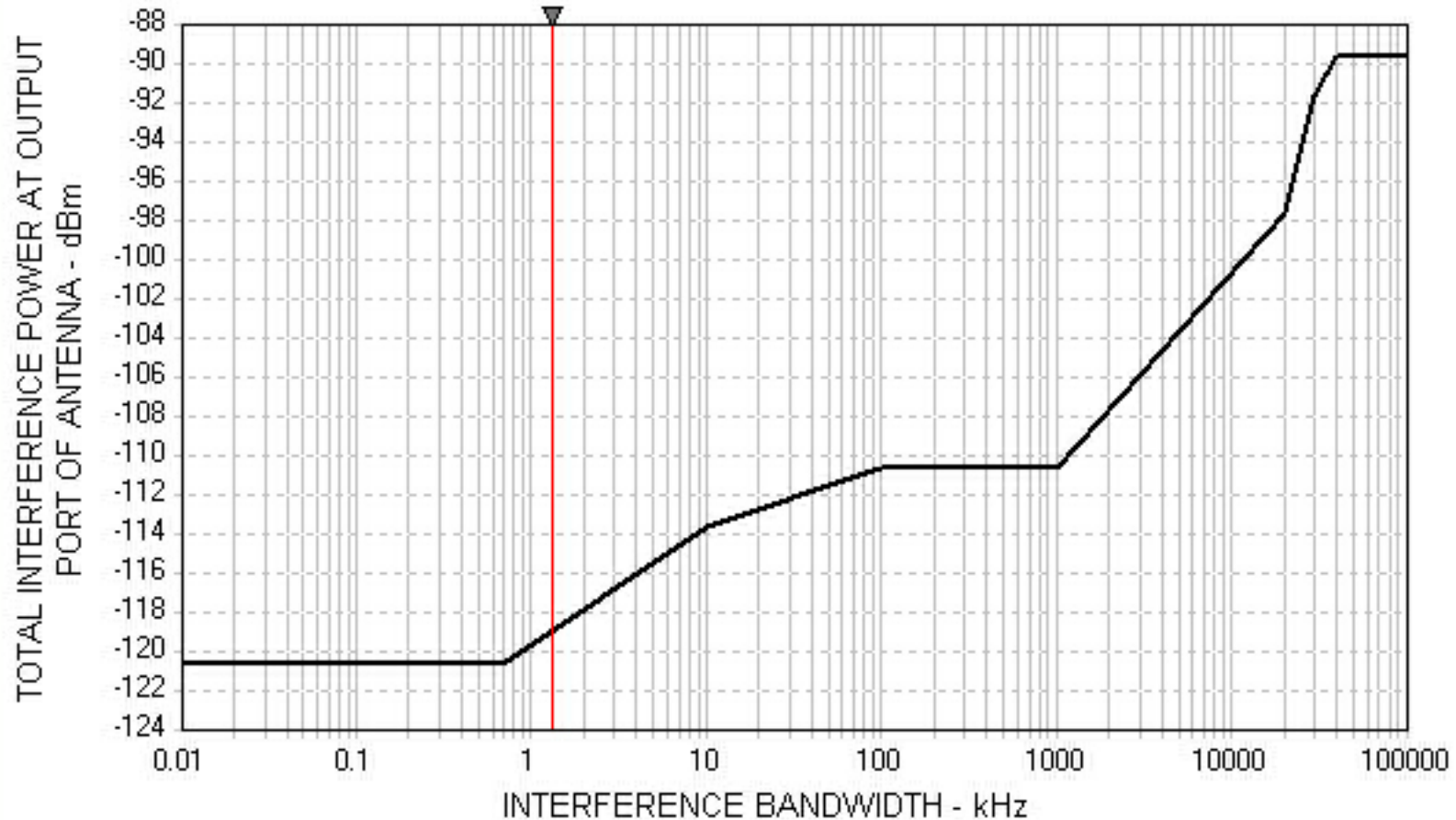

DIRECTIONS: Use "up" and "down" buttons to move cursor left and right, or use numeric buttons to type value and press "enter"

BANDWIDTH

1.30 kHz

INTERFERENCE POWER

-118.9 dBm

Interference Level vs. Interference Bandwidth