



CNG-EbNo Series
**Precision SNR
Generator**

Data Sheet



Count on the noise leader

CNG-EbNo Series Precision SNR Generators

The CNG-EbNo is a fully automated instrument that sets and maintains a highly accurate ratio between a user-supplied carrier and internally generated noise, over a wide range of signal power levels and frequencies.

The CNG-EbNo gives system, design, and test engineers in the cellular/PCS, satellite and military communication industries a cost-effective means of obtaining higher yield through automated testing, plus increased confidence from repeatable, accurate test results.



Features

Multiple Operating Modes

The CNG-EbNo provides five operating modes: carrier-to-noise (C/N), carrier-to-noise density (C/N_0), bit energy-to-noise density (E_b/N_0), carrier-to-interferer (C/I), and power meter. The instrument can also be used as a precision noise generator.

Custom Configurations

The CNG-EbNo is available in a variety of configurations to meet your specific testing needs. Applications include: military communications, WCDMA, SATCOM, NASA TDRSS, CableTV, HDTV, IS-95, CDMA, TSMa, UMTS, GPRS L-band modems, Milstar, Inmarsat, Intelsat, and general purpose.

Direct Display of E_b/N_0 , C/N, C/I, or C/No

The 6.25" color TFT touch screen provides simultaneous read-out of all significant input and output signal levels relating to the chosen operating mode, including carrier-to-noise ratios.

Accuracy of 0.2 dB RSS

A special, large-dynamic-range power meter measures both the signal and the noise, which allows the CNG-EbNo to set the desired ration to within ± 0.2 dB. Special configurations can provide improved accuracy.

Bit Rate Entry of 1 bps to 999 Mbps and above

In bit energy-to-noise density testing (E_b/N_0), the instrument automatically calculates noise density based on the user specified bit rate.

Variable Output Power

Output power is user-specified and can be set within the range of -55 dBm to +5 dBm.

True RMS Power Meter

The digital power meter is custom designed to cover the frequency range of the particular instrument. It can measure signals and noise accurately with Gaussian Noise crest factors up to 18 db.

Direct Testing at both RF and Microwave Frequencies

In configurations that cover two separate frequency ranges, measurements can be made directly without the need for special conversion circuitry.

Optional Tracking Feature

This function is intended for users with an unstable input signal source who wish to perform accurate long-term testing at a specified E_b/N_0 ratio. The tracking option works as an automated gain control (AGC) device, correction for input signal drift up to 0.2 dB resolution. The carrier output level is kept constant and, therefore, so is the E_b/N_0 ratio.

Setting Precision C/N Ratios

The CNG-EbNo accurately sets carrier-to-noise ratios using the substitution calibration method. This method eliminates the effects of any non-linearity in the measuring device, in this case the power meter. This is done by setting the signal and the noise to the same power level at the power meter input. (See the functional block diagram). The noise power is then offset by the desired ratio. The primary source of inaccuracy within the unit is the attenuator that varies the noise power, and Noisecom uses the most accurate components available. Secondary effects such as thermal drift are negligible since the noise and the power are measured within a very short time frame.

Active components in the instrument that could be attributed to long-term drift are common to both the signal and noise path, so variations in these components do not affect the calibrated ratio. The unit's linear phase and amplitude signal path ensures that the desired signal passes through undistorted.

Since the CNG-EbNo automatically compensates for parameters like bit rates and bandwidth, taking measurement is as simple as pressing a button. Operating modes, function and parameters are set using the front panel touch screen controls.

Meter – In this mode, the instrument functions as a true RMS power meter, and uses various averaging methods to ensure more accurate readings.

Measurements are made through couplers, allowing the signal to pass through to the output connector unaltered by the meter circuitry.

E_b/N_o – The instrument automatically sets up a desired E_b/N_o quickly and accurately. Based on the user-specified carrier output level, output E_b/N_o ratio, and bit rate, the instrument automatically calculates the required noise density.

C/N – This mode sets the specified carrier output level and the total noise power in the system bandwidth to the desired ratio.

C/N_o – To obtain a specific C/N_o ratio, set the instrument to E_b/N_o mode and enter zero for the bit rate. All other functions are the same as the E_b/N_o mode.

C/I – This mode sets the specified carrier output level and the user interference input power in the system bandwidth to the desired ratio.

GEN – The instrument can also function as a precision noise generator. Simply select the mode and enter the required noise density. The unit's internal noise source provides the desired signal.

Status Indicators and Display Screen – Front panel indicators and the 6.25" touchscreen display provide constant feedback on the instrument state and settings.

Data Entry and Function Selection – Instructions and data are easily entered through the front panel keypad. The instrument can also be controlled through the standard rear panel GPIB (optional), Ethernet, TCP/IP, or optional RS-232C, RS-422 or RS-423 interfaces.

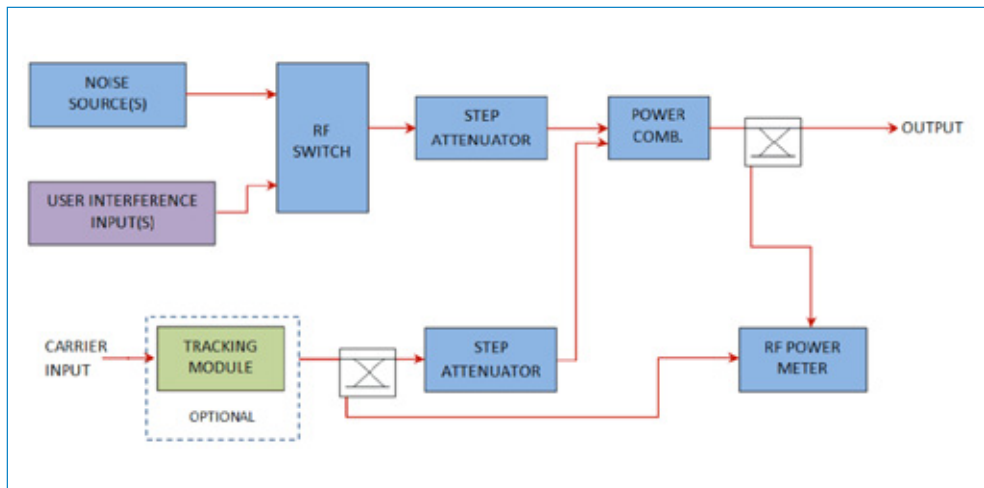

Simplified Functional Block Diagram

The internal AWGN precision noise source is summed with the user supplied carrier signal. The unit generates extremely precise E_b/N_o ratios over a broad range of input or output power.

Carrier to Noise Ratio (C/N)

What is it?

C/N is the ratio of the relative power level to the noise level in the bandwidth of a system.

Why we need it?

Allows to analyze if a carrier can still be recognized as such, or if it is obliterated by ambient and system noise. C/N Provides a value for the quality of a communication channel.

How to measure?

The quality of the system is usually determined through BER plots against C/N.

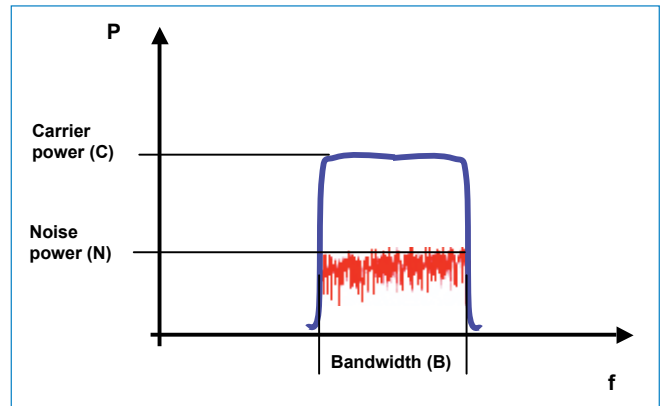

Noise Spectral Density (N₀)

What is N₀?

Noise spectral density (N₀) is defined as the amount of (white) noise energy per bandwidth unit (Hz).

$$N_0 = N / B$$

N₀ is often expressed as

$$N_0 = kT$$

Where

k is the Boltzmann's constant in Joules per Kelvin [J/K]

T is the receiver system noise temperature in Kelvin [K]

The units of N₀ are Joules [J], Watts/Hz [W/Hz] or Watts * s [Ws]. All three units express the very same metric.

$$[J] = [W / Hz] = [Ws]$$

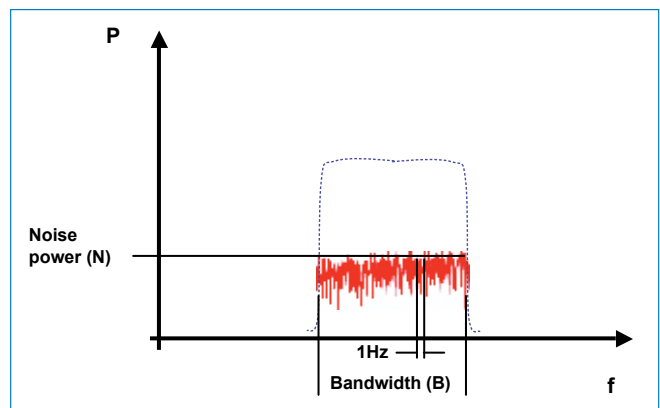

Carrier to Noise Density Ratio (C/N_0)

What is it?

C/N_0 is the ratio of the power level to the noise power spectral density (normalized noise level relative to 1 Hz) in a system.

Why we need it?

Similar as C/N but C/N_0 does not factor the actual noise bandwidth in. This simplifies analysis of systems where variation of the (utilized) BW may apply.

How to measure?

As C/N , C/N_0 is usually determined through BER plots

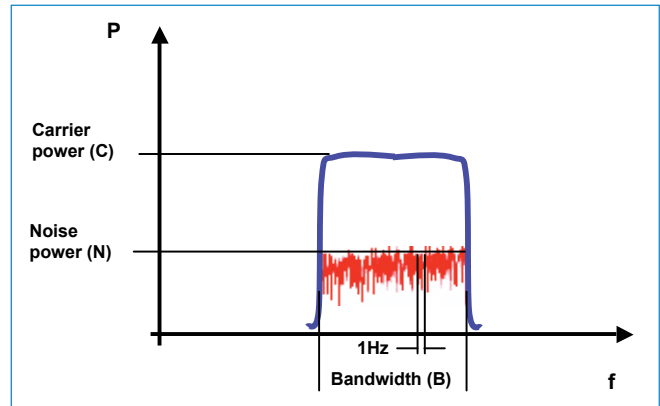

Energy per bit (E_b)

What is E_b ?

Energy per information bit (i.e. the energy per bit net of FEC overhead bits). Carrier power divided by actual information bits.

$$E_b = C/R$$

Where

C is the carrier power

R is the actual information bit rate.

Why we need it?

Using the E_b rather than overall carrier power (C) allows comparing different modulation schemes easily.

The units of E_b are Joules [J], Watts/Hz [W/Hz] or Watts * s [Ws]. All three units express the very same metric.

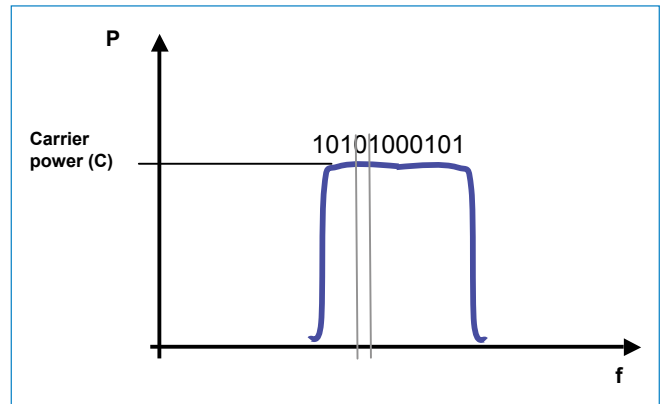

Simplified depiction of E_b . Bits in modulation schemes are not as shown directly linked to a certain frequency.

Energy per Bit to Noise Power Density (E_b/N_0)

What is it?

E_b/N_0 is the ratio of the Energy per Bit divided by the noise power density.

Why we need it?

Allows comparing bit error rate (BER) performance (effectiveness) of different digital modulation schemes. Both factors are normalized, so actual bandwidth is no longer of concern.

How to measure?

Modulation schemes are compared through BER plots against E_b/N_0 . E_b/N_0 is a dimensionless ratio.

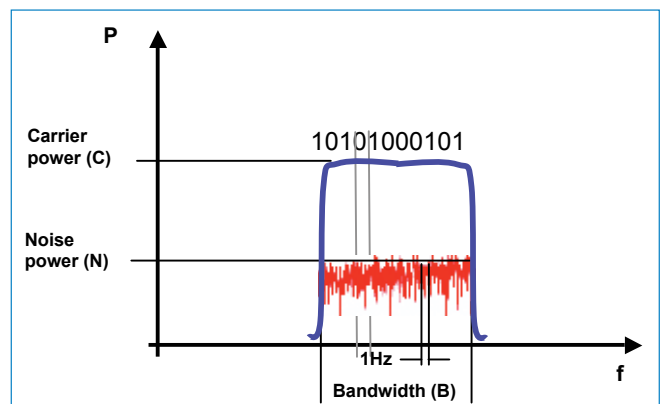

Performance of BER vs E_b/N_0

This block diagram shows an example of typical satellite modem loop test set up from where it is possible to find the ideal performance of BER vs E_b/N_0 . The CNG-EbNo tester sets up the E_b/N_0 and a standard BER test equipment measures the bit error rate. Plotting BER vs. E_b/N_0 produces a waterfall like curve to its shape when plotted in a logarithm graph.

E_b/N_0 is commonly used with modulation and coding designed for noise-limited rather than interference-limited communication systems, and for power-limited rather than bandwidth-limited communication systems. Examples of power-limited systems include spread spectrum and deep-space, which are optimized by using large bandwidths relative to the bit rate.

- MSK:** Minimum shift keying
- PSK:** Phase shift keying
- DBPSK:** Differential binary phase shift keying
- DQPSK:** Differential quadrature phase shift keying
- OOK:** On-off keying
- OFSK:** Orthogonal frequency shift keying

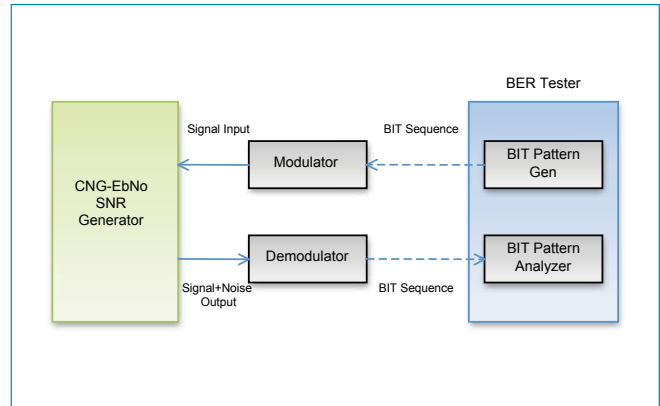

Block diagram of typical satellite modem loop test up

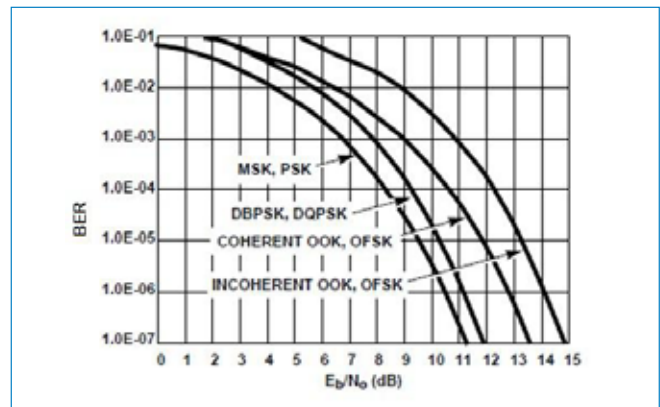

Example of the relationship between BER and E_b/N_0

Carrier to Interference Ratio (C/I, CIR)

What is it?

C/I is the quotient between the average received modulated carrier power C and the average received co-channel interference power I. (i.e. cross-talk, from other transmitters than the useful signal).

Why we need it?

Allows analysis and rating of channel robustness against neighbor channels.

How to measure?

As C/N and C/No, C/I are usually analyzed through BER plots.

$$C / I = C / (I_1 + I_2 + I_n)$$

C / I is a dimensionless ratio

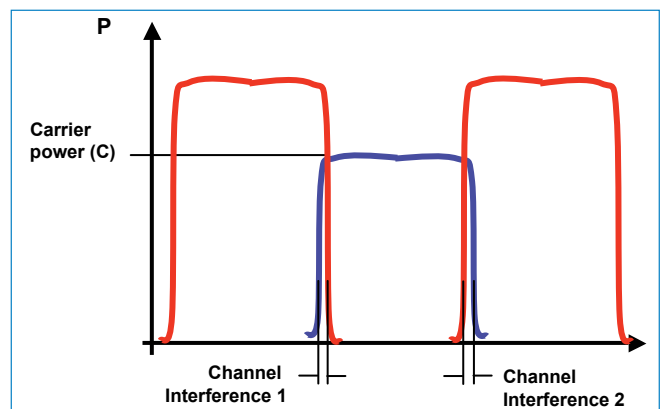

Correlation: C/N, C/No and Eb/No

$$C/N = C/(N_o * B) = (E_b/N_o) * (R/B)$$

$$E_b/N_o = (C/N) * (B/R)$$

$$N_o = (N * E_b * R) / B * C$$

$$C/N \text{ dB} = 10_{\log} (E_b/N_o) + 10_{\log} (R/B)$$

CNG EbNo vs. Spectrum Analyzer

The CNG EbNo offers a variety of advantages over discrete instruments when measuring C/N, C/No, E_b/N_o or C/I:

- Automated procedure, therefore repeatable measurements provided quickly
- Highest accuracy through substitution calibration method
- Automated calculation of results
- Customer specific configuration depending on the application

Specifications

Operating modes

Carrier-to-noise (C/N), carrier-to-noise density (C/No), bit energy-to-noise density (E_b/N_o), carrier-to-interferer (C/I), noise generator, power meter

Carrier Path

Input power range	-55 dBm to +5 dBm
Maximum input power	+21 dBm (with no damage)
Output power range	-55 dBm to +5 dBm
Nominal gain	±1.0 dB
Gain resolution	0 to -60 dB in 0.1 dB steps
Gain flatness	±0.2 dB for 70 MHz ±20 MHz ±0.3 dB for 140 MHz ±40 MHz ±0.4 dB for others
Group delay	±0.20 ns/40 MHz for frequencies above 20 MHz
Third-order intercept point	+29 dBm typical
Tracking range (Ubopt01)	+4 dB to -4 dB
Tracking update rate	100 milliseconds, nominal

Noise path

Output power range	-55 dBm to +5 dBm
Flatness	±0.2 dB/40 MHz ±0.3 dB/80 MHz ±0.4 dB/200 MHz ±0.5 dB/300 MHz
Attenuation range	60 dB (0.1 dB steps)
Ratio accuracy	±0.2 dB RSS, ±0.3 dB WCU
Power meter range	-55 dBm to +5 dBm
Power meter accuracy	±0.5 dB
Power meter averaging	10 to 65,535. Each sample requires approximately 2.2 ms
Control	Local, TCP/IP, GPIB (optional)
Interferer input	-4 dBm ±2 dB, frequency range is equal to the noise bandwidth
RF connectors	BNC-75 Ω below 800 MHz, N-type female 50 Ω above 800 MHz

Primary power

Voltage	85 to 264 VAC
Frequency	47 to 63 Hz
Consumption	2 amps, maximum
Fuse	2 A
Operating temperature	0° to 50° C
Dimensions	17" W x 5.25" H x 17.5" D

Ordering Information

Model Number	Frequency Range	Applications
CNG-EbNo-5	1 to 10 MHz	Baseband
CNG-EbNo-45	5 to 90 MHz	General Purpose
CNG-EbNo-70	50 to 90 MHz	General purpose/SATCOM
CNG-EbNo-IF1	50 to 90 MHz 100 to 180 MHz	Intelsat, SATCOM
CNG-EbNo-IBS/IDR	50 to 90 MHz 68 to 72 MHz 100 to 180 MHz	Intelsat, SATCOM
CNG-EbNo-225	50 to 400 MHz	General Purpose
CNG-EbNo-255	240 to 270 MHz	SATCOM
CNG-EbNo-370	350 to 390 MHz	NASA TDRSS
CNG-EbNo-CATV	50 to 860 MHz	Cable TV, HDTV
CNG-EbNo-900	800 to 1000 MHz	Cellular
CNG-EbNo-750	650 to 850 MHz	Iridium, LTE
CNG-EbNo-892	822 to 962 MHz	Cellular
CNG-EbNo-892/1850	822 to 962 MHz 1710 to 1990 MHz	Cellular PCS
CNG-EbNo-1550	950 to 2150 MHz	L-band modems, Satellite IF Loopback Testing
CNG-EbNo-1545	1530 to 1560 MHz	Inmarsat
CNG-EbNo-1850	1710 to 1990 MHz	J-STD-008 (CDMA) 3G Mobile Telecom
CNG-EbNo-2050	1900 to 2200 MHz	Wideband CDMA
CNG-EbNo-2050L	1700 to 2400 MHz	Cellular/PCS
CNG-EbNo-2105	1710 to 2500 MHz	3G Mobile Telecom, CDMA Wireless local loop
CNG-EbNo-2442	2400 to 2484 MHz	802.11b Wireless LAN WiFi, Bluetooth
CNG-EbNo-2450	2200 to 2700 MHz	PCS
CNG-EbNo-5500	5000 to 6000 MHz	802.11a Wireless LAN
CNG-EbNo-WiMAX	3400 to 5800 MHz	802.16 WiMax
CNG-EbNo-20000	18 to 22 GHz	Custom frequency ranges available

Call Noisecom for custom configurations

Specification values apply following a 30 minute warmup

Options

UEopt01	Automatic gain control to maintain constant carrier power level
UEopt03	50 Ω input and output impedance ¹
UEopt04	RS-232C, RS-422, or RS-423 interface ²
UEopt05	230 VAC, 50 Hz
UEopt15	19" rack mount
UEopt16	GPIB
UEopt17	Removable hard drive ³

¹ Below 800 MHz, standard impedance is 75 Ω . Above 800 MHz, 50 Ω is assumed.

² In addition to standard TCP/IP

³ Highly recommended for military

Wireless Telecom Group Inc.

25 Eastmans Rd
Parsippany, NJ 07054

Sales Offices

Parsippany, NJ
United States
Tel: +1 973 386 9696
Fax: +1 973 386 9191
www.noisecom.com

© Copyright 2010
All rights reserved.

NC/CNG-EbNo/0910/EN
Note: Specifications, terms and conditions are subject to change without prior notice.