

# Radar Signal Generator

## 19" RACK MOUNT RADAR SIGNAL GENERATOR SYSTEMS

Ideal for creating a variety of scenarios for use in extensive training. Also ideal for receiver testing applications.

## PORTABLE RADAR SIGNAL GENERATOR SYSTEMS

For use in field, maritime and other applications where portability is crucial

The transmit antenna and amplifier are integrated, which allows the simulator and the receiver being tested, to be placed in separate locations.



- Replicates real radar signal characteristics (Frequency, Phase, Pulse, Modulation, SCAN).
- Simulation Scenarios: AOA Simulation, Radar Activity, Virtual Missions.
- Ideal for Electronic Warfare training and Radar receiver testing.
- 19" Standard Rack Mountable and Portable models are available.
- Signal data library with up to 1024

AWT(G) Radar Simulators generate a variety of Radar Signals. The Simulators are ideal for radar receiver testing and in training Radar Operators on object detection, recognition and Electronic Warfare (EW). The simulators offer variety of simulation capabilities; including Radar Warning Receivers (RWR), Missile Warning Receivers (MWR) and other Electronic Warfare (EW) Receivers.

AWT's Radar Simulator can generate up to 128 simultaneous CW or Pulsed signals. An intuitive graphical user interface (GUI) makes it easy to program signal parameters. Geographic Information System (GIS) tools are also available (optional). The receiving band(s) are developed to customer specifications. They are available in the range from 0.5 GHz and 40 GHz.

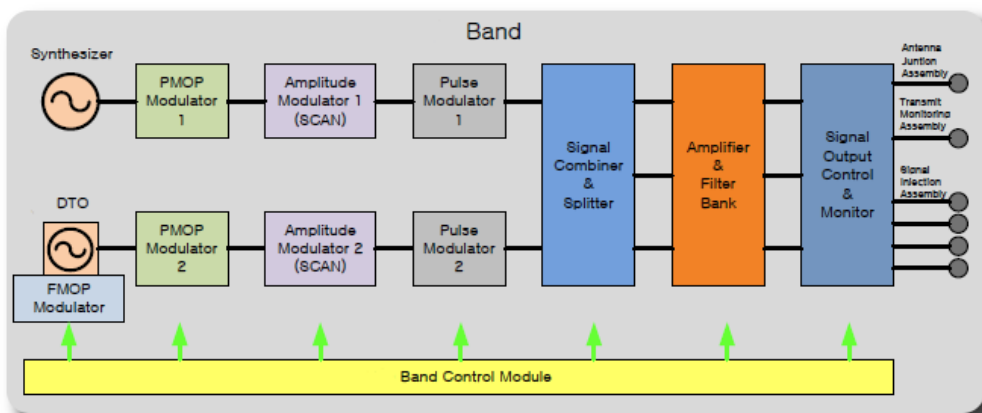

Radar Signal Generator - Block diagram (single bank).  
(Expandable to eight (8) banks in one simulator)



# Simulator & Threat Software

## SCENARIOS

### AOA Simulation

- DF test using Amplitude and Angle of the Antenna.
- Antenna pattern measurement
- Signal level change at scheduled time

### Radar Activity

- Search Radars
- Acquisition Radars
- Tracking Radars

### Virtual Missions

RF Signal Parameter Management software runs on Windows operating systems. RF signals are composed of frequency, pulse and SCAN characteristics. All parameters are editable in an easy to use and clearly laid out user interface.

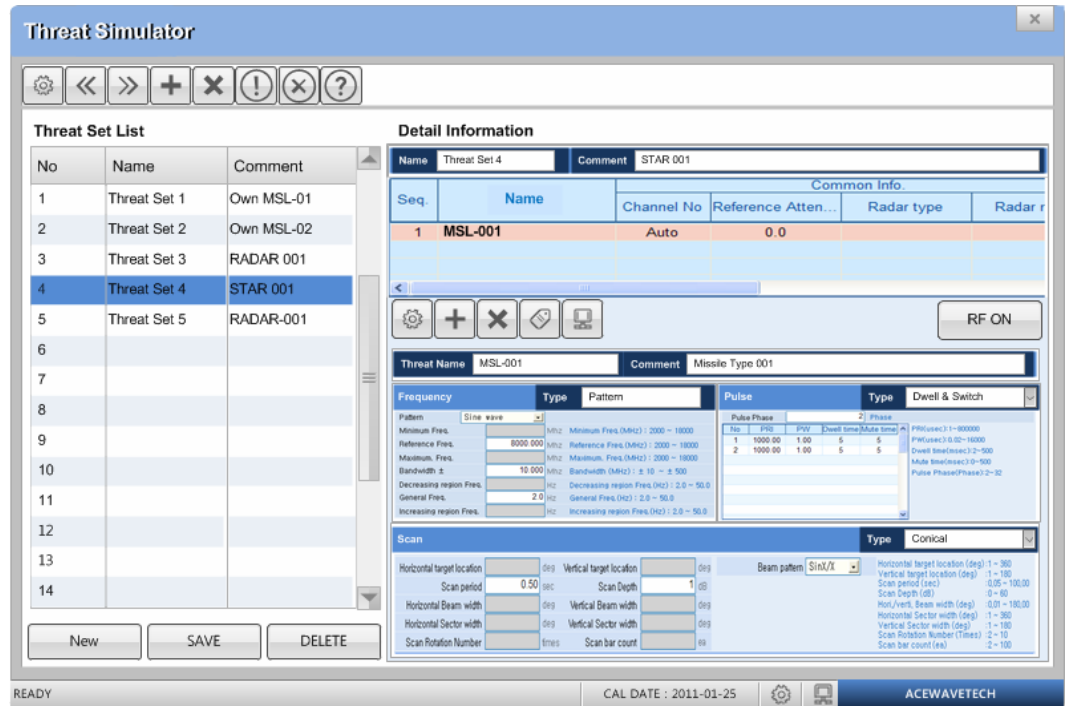

The Editor Screen displays the configuration for a specific threat set. It includes a 'Threat Set List' on the left, a 'Detail Information' panel on the right, and a status bar at the bottom.

No	Name	Comment
1	Threat Set 1	Own MSL-01
2	Threat Set 2	Own MSL-02
3	Threat Set 3	RADAR 001
4	Threat Set 4	STAR 001
5	Threat Set 5	RADAR-001
6		
7		
8		
9		
10		
11		
12		
13		
14		

Name		Comment	
Threat Set 4		STAR 001	

Seq	Name	Channel No	Reference Atten...	Radar type	Radar r
1	MSL-001	Auto	0.0		

Minimum Freq.	Reference Freq.	Maximum Freq.	Bandwidth	Decreasing region Freq.	General Freq.	Increasing region Freq.
8000.000 MHz	2000 - 18000 MHz	2000 - 18000 MHz	± 10 - ± 500 MHz	2.0 - 50.0 MHz	2.0 - 50.0 MHz	2.0 - 50.0 MHz

No	PRI	PW	Dwell time	Mute time	Phase
1	1000.00	1.00	5	5	Phase(1)=1-80000
2	1000.00	1.00	5	5	Phase(2)=10-18000

Horizontal target location	Vertical target location	Beam pattern	Horizontal target location (deg)	Vertical target location (deg)
0.50 sec	1 dB	SinX/X	1 - 360	1 - 180

Editor Screen

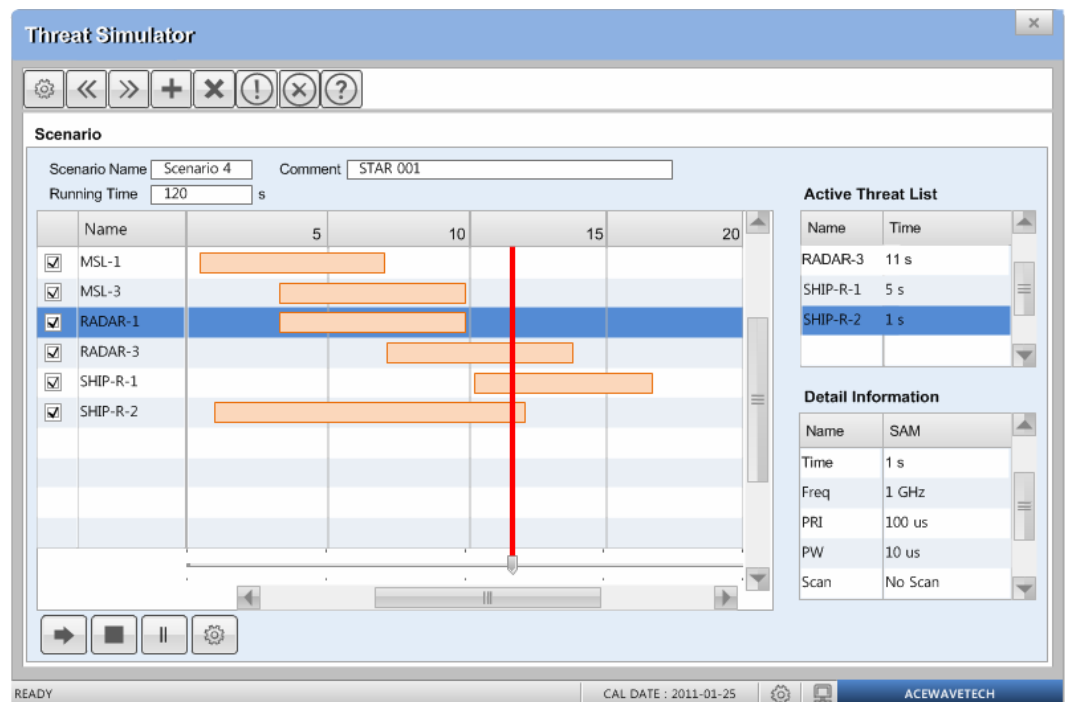

The Threat Sequencer Screen shows a scenario timeline and active threat list. It includes a 'Scenario' section, a timeline with threat bars, and a 'Detail Information' panel.

Scenario Name: Scenario 4, Comment: STAR 001, Running Time: 120 s

Name	Time
RADAR-3	11 s
SHIP-R-1	5 s
SHIP-R-2	1 s

Name	SAM
Time	1 s
Freq	1 GHz
PRI	100 us
PW	10 us
Scan	No Scan

Threat Sequencer Screen

# Radar Scan Types

SCAN Type	Antenna Motion	Receiver Signal Strength
Electronic	Agile Beam	
Conical		
TWS		
Steady		
Lobe Switching		
Circular		
Sector		
Helical		
Spiral		
Raster		
Bi-Directional		

# Specifications

## PRODUCT QUALITY

AWT is committed to providing our customers with products meeting the highest quality standards. All AWT products undergo thorough quality checks and are ISO 9001 and ISO 14001 certified.

## MORE INFORMATION

For more information about any of our products or services contact one of our sales offices and channel partners, or visit our Web site:  
[www.awt-global.com](http://www.awt-global.com)

## SALES OFFICES

### AWT-Global Headquarter

2001 Route 46  
Waterview Plaza, Suite 310 - 71  
Parsippany, New Jersey 07054  
USA

p: +1 (973) 321-3423  
f: +1 (973) 402-8912  
e: [info@awt-global.com](mailto:info@awt-global.com)

### AWT-Global Nevada

11309 Asilo Bianco Avenue  
Las Vegas, Nevada 89138  
USA

p: +1 (702) 358-0290  
f: +1 (817) 288-0521  
e: [thomas.lee@awt-global.com](mailto:thomas.lee@awt-global.com)

Frequency	
Range	0.5 – 40 GHz (in customer specified bands)
NATO Bands	C, D, E, F, G, H, I, J, K
IEEE Bands	UHF (upper), L, S, C, X, Ku, K, Ka
Resolution	1 MHz
Accuracy	1 kHz (higher accuracies on request) 2 MHz (VCO or DTO)
Type	Fixed, Agile (Sinusoid, Saw-Tooth, Triangular, Rectangular, Random), Hopping (up to 256 /sec)

Pulse	
Type	CW, Stable, Jitter, Stagger (32 Steps), Dwell & Switch, Random
Width Range	0.05 – 225 us
Repetition Interval	1us – 1 sec (longer possible)
Density	Up to 1,000,000 pulses/sec (PPS)
FMOP	Linear, Non-Linear, (FM Bandwidth depends on PW, 40 MHz max)
PMOP Agile	Bi-Phase, Quadratic-Phase

Frequency Modulation on Pulse (FMOP)	
Pattern	Linear, Non-Linear, Chirp Up/Down
Agile	Sine, Triangular
Range	10 – 512 MHz
Accuracy	1 MHz

Phase Modulation on Pulse (PMOP)	
Pattern	Bi-Phase, Quadratic Phase
Change Time	< 50ns
Accuracy	better than 20°

SCAN	
Types	Electronic (Agile Beam), Conical, TWS, Steady, Sector, Lobe Switching, Circular, Helical, Raster, Bi-Directional, User defined
Rate	50ms – 10 sec
AM	0 – 40 dB

Output	
Number of RF Signals per bank	1 CW + 1 Pulse Doppler Signal or, 1 CW + 16 Pulse Signals, or 17 Pulse Signals
Ports per bank	1 Vertical Polarization, 1 Horizontal Polarization, 1 Monitoring
Power (signal)	> 15 dBm (other power levels on request)
Monitoring port	> 5 dBm (other power levels on request)

Communication Interfaces	
Ethernet (IEEE 802.3), USB, RS-232	

Dimensions / Weight / Environment / Electrical	
Dimensions	Depends on model and configuration
Weight	Depends on model and configuration
Power	110-240V +/- 10% Up to 30 minutes battery operation with maximal transmit power (portable instruments only)
Power Consumption	Depends on model and configuration

